

# Emergency Light Fitting for Fluorescent Lamps

Series EXLUX 6008 / 6408



www.stahl.de



10068E00

- > As pendant light fitting or side entry lamp
- > Version with 2 lamps: 18 W and 36 W
- > Central locking
- > Weekly functional test
- > Light duration test of the emergency lighting once a year

E2



The lights of the Series **EXLUX 6008** and **EXLUX 6408** can be used as emergency lighting

Zone	ATEX / IECEx						Zone	Class I (NEC 505) (NEC 506)						Division	Class I		Class II		Class III			
	0	1	2	20	21	22		0	1	2	20	21	22		1	2	1	2	1	2		
EXLUX 6008 For use in:		x			x	x	EXLUX 6008 For use in:		x	x					EXLUX 6008 For use in:		x	x	x	x	x	x
EXLUX 6408 For use in:				x <sup>1)</sup>	x <sup>1)</sup>	x <sup>1)</sup>	EXLUX 6408 For use in:			x					EXLUX 6408 For use in:		x	x	x	x	x	x

<sup>1)</sup> only ATEX

**WebCode 6008A**

## Emergency Light Fitting for Fluorescent Lamps

Series EXLUX 6008 / 6408

**Selection Table**

Version	Lamps	Battery	Lighting hours	Order number	Weight kg
6008 Standard light	2 x 18 W	7 Ah	1.5 / 3 h (emergency light)	<b>6008/522-9011-7147</b>	8.200
	2 x 36 W	7 Ah	1.5 / 3 h (emergency light)	<b>6008/542-9011-7147</b>	10.400
6008 Side entry lamp	2 x 18 W	7 Ah	1.5 / 3 h (emergency light)	<b>6008/922-9071-7147</b>	10.800
	2 x 36 W	7 Ah	1.5 / 3 h (emergency light)	<b>6008/842-9081-7147</b>	13.000
6408 Standard light (Zone 2, 21, 22)	2 x 18 W	7 Ah	1.5 / 3 h (emergency light)	<b>6408/522-9011-7147</b>	8.000
	2 x 36 W	7 Ah	1.5 / 3 h (emergency light)	<b>6408/542-9011-7147</b>	10.200
6408 Side entry lamp (Zone 2, 21, 22)	2 x 18 W	7 Ah	1.5 / 3 h (emergency light)	<b>6408/922-9071-7147</b>	10.600
	2 x 36 W	7 Ah	1.5 / 3 h (emergency light)	<b>6408/842-9081-7147</b>	12.800

**Order Number Supplement**

Through wiring	without	<b>6.08 / . . . . . 0 . . . . .</b>
	with 4 conductors (18 W only with spring-cage terminal)	<b>6.08 / . . . . . 4 . . . . .</b>
	with 6 conductors (18 W only with spring-cage terminal)	<b>6.08 / . . . . . 6 . . . . .</b>
Cable glands	Standard 1 cable gland M25 x 1.5 and 2 stopping plugs M25 x 1.5	<b>6.08 / . . . . . 1 . . . . .</b>
	Special Specify non-standard gland parts	<b>6.08 / . . . . . 9 . . . . .</b>
Emergency duration test	with	<b>6.08 / . . . . . . . . . . 7</b>
	without	<b>6.08 / . . . . . . . . . . 8</b>
<p><b>Note:</b> The continuous operation is set in factory; by removing a jumper and connecting an external switch, the switchable continuous operation can be activated. The lights are delivered without fluorescent lamps and assembly parts. These parts must be ordered separately.</p>		

**Explosion Protection**

<b>Global (IECEx)</b>		
Version	<b>6008, Zones 1, 21, 22</b>	<b>6408, Zones 2, 21, 22</b>
Gas and dust	IECEx PTB 07.0053 Ex d e mb IIC T4 Ex tD A21 IP66 T80°C	-- -- --
<b>Europe (ATEX)</b>		
Version	<b>6008, Zones 1, 21, 22</b>	<b>6408, Zones 2, 21, 22</b>
Gas	PTB 97 ATEX 2032 ⊕ II 2 G Ex d e mb IIC T4	SNCH 03 ATEX 3519 (Zone 2) ⊕ II 3 G EEx nA II T4 (Zone 2)
Dust	PTB 97 ATEX 2032 ⊕ II 2 D Ex tD A21 IP6. T80°C	SNCH 03 ATEX 3518 (Zone 21) SNCH 03 ATEX 3519 (Zone 22) ⊕ II 2 D IP66 T80°C, T90°C (Zones 21, 22) T80 °C at T <sub>a</sub> = + 40 °C T90 °C at T <sub>a</sub> = + 50 °C
<b>Certificates and approvals</b>		
Version	<b>6008, Zones 1, 21, 22</b>	<b>6408, Zones 2, 21, 22</b>
Certificates	IECEx, ATEX, Brazil (UL do Brasil), India (PESO), Canada (CSA), Kazakhstan (GOST-K), Russia (GOST-R), Ukraine (GOST-U), USA (FM), Belarus (GOST-B), Serbia (IZP), Korea KGS), China (CQST)	ATEX, Belarus (GOST-B)
Other approvals	ship approval (GL)	--
<b>Further parameters</b>		
Marking (CE)	CE 0158	CE 0158

# Emergency Light Fitting for Fluorescent Lamps

Series EXLUX 6008 / 6408

STAHL

## Technical Data

### Electrical data

Rated voltage	220 ... 254 V, 50 / 60 Hz 110 ... 127 V, 50 / 60 Hz available on request
Disconnection of the light	<b>When opening the light</b> Switch with safety lock; when opening the central lock, all poles of the voltage supply to the ballast are disconnected; contacts of the switching element are NC contacts, they can only switched on again when the lamp cover and the central locking system are closed. <b>In case of a lamp fault</b> , the electronic ballast disconnects the defective lamp from the power supply.

### Luminous characteristics

Lamps	2 x 18 W; 2 x 36 W
Measures for light guidance	<b>Standard:</b> deep bowl, internal reflector of the lights are painted in white colour. Colour: signal white RAL 9003; lateral dazzle limitation in the lamp cover. <b>Special feature:</b> Additional reflector (can be easily mounted), broad deep bowl, polished aluminium

### Ambient conditions

Version	<b>6008, Zones 1, 21, 22</b>	<b>6408, Zones 2, 21, 22</b>
Ambient temperature	- 30 ... + 50 °C - 5 ... + 40 °C operationable	Standard operation: - 20 ... + 50 °C Battery operation: - 5 ... + 50 °C charging, - 20 ... + 50 °C discharging

### Mechanical data

Degree of protection	IP66 / IP65 (IP64 when using the breather 8162)
Protection class	I (with internal PE connection)
Material	
Enclosure material	Polyester, glass fibre reinforced, colour: white, similar to RAL 9010
Lamp cover	Polycarbonate; as an option an aromatic-resistant paint can be used
Gasket	Polyurethane foam gasket in the lamp cover
Lamp locking	Central locking which can be opened/closed using a socket key M8 / wrench size 13, hinged lamp cover

### Mounting / Installation

Cable entry	<b>Standard light</b> <b>Standard:</b> Connection side: 1 screw connection M25 x 1.5 and 1 stopping plug M25 x 1.5; opposite side: 1 stopping plug M25 x 1.5 <b>Special:</b> M20 in moulded material or metal Possible holes: 2 x NPT 1/2" or 1 x NPT 3/4" for side entry lamp <b>Side entry lamp</b> <b>Factory-mounted pole mount adapter:</b> 18 W: Use the cable gland of the standard lamp. 36 W: The cable is inserted into the light through the pole mount adapter. 1 x M25 x 1.5 stopping plugs 8290 (enclosed in the delivery) 1 x M25 x 1.5 breathing gland (enclosed in the delivery) The cable is sealed by means of a gland M32 x 1.5. <b>If the pole mount adapter is subsequently mounted</b> (possible for lamps 18 W and 36 W): Use the cable gland of the standard light
Connection	<b>Standard:</b> Terminal block with cover designation: L1; N; PE; L' (L' = switched phase); terminal capacity: max. 2 x 6 mm <sup>2</sup> (single-wire); 2 x 4 mm <sup>2</sup> (fine-stranded wire) <b>Special</b> Terminal block with additional terminals for through wiring, 4 poles (terminal designation: L1 + N + PE, L') or 6 poles (terminal designation: L1 + L2 + L3 + N + PE, L')
Through wiring	Lights are available with internal through wiring, 4 or 6 conductors at 18 W are only possible in connection with a spring cage terminal. The through wiring kit is retrofittable; cross section 2.5 mm <sup>2</sup> for max. 16 A

E2

# Emergency Light Fitting for Fluorescent Lamps

Series EXLUX 6008 / 6408

Technical Data																
Assembly	<p><b>Looping of the cables</b>  <b>Standard light</b>            On the connection side, there are two possibilities M25 x 1.5 for the looping of the connecting line (entry and exit on one side), also possible with lights subsequently fitted with pole mount adapter.</p> <p><b>Through wiring</b>  <b>Standard light</b> Lights are available with internal through wiring. Entry and exit holes for connecting cables are positioned on the opposite sides. A through-wiring kit can be installed later (see accessories). Terminals: see Technical data. Wiring cross-section 2.5 mm<sup>2</sup> for max. 16 A</p> <p><b>Assembly</b>  <b>Standard light</b>            Standard: 2 x M8 insert nuts in the enclosure            Special: Mounting grooves in the enclosure for the use of fastening and ceiling rails for variable light installation (variable mounting distances for lights 18 W: 312 ... 465 mm; 36 W: 670 ... 865 mm)            The pole mount adapter is mounted in factory and can be retrofitted on the standard light  <b>Side entry lamp</b>            The light is mounted on a tube adapter with the diameter 42 mm and fixed by means of a clamp.            The pole mount adapter is mounted in factory; it is also possible to install it later on the standard light.            Insertion of the connecting cable:  <b>If a factory-mounted pole mount adapter is used:</b>            The cable is lead through the pole mount adapter into the light. The cable is sealed by means of a gland M32 x 1.5. (only possible for 36 W lights)  <b>If a retrofitted pole mount adapter is used:</b>            use the gland of the standard light</p>															
<b>Emergency light electronics</b>																
Operating modes	Continuous operation, continuous operation with emergency light blocking and stand-by switching															
Battery charge	Intelligent battery management, controlled microprocessor (charging time max. 14 h) total discharge protection to avoid a pole reversal															
Emergency light mode	During emergency light operation, only one lamp is used. This results in a reduced lighting power (see emergency light service time)															
Emergency light service time	<table border="1"> <thead> <tr> <th>Battery capacity</th> <th>Emergency light service time</th> <th colspan="2">Emergency lighting power</th> </tr> <tr> <th></th> <th></th> <th>Lights 18 W</th> <th>Lights 36 W</th> </tr> </thead> <tbody> <tr> <td rowspan="2">7 Ah</td> <td>1.5 h</td> <td>100 %</td> <td>60 %</td> </tr> <tr> <td>3 h</td> <td>60 %</td> <td>30 %</td> </tr> </tbody> </table>	Battery capacity	Emergency light service time	Emergency lighting power				Lights 18 W	Lights 36 W	7 Ah	1.5 h	100 %	60 %	3 h	60 %	30 %
Battery capacity	Emergency light service time	Emergency lighting power														
		Lights 18 W	Lights 36 W													
7 Ah	1.5 h	100 %	60 %													
	3 h	60 %	30 %													
Switchover voltage	from mains to battery operation for $U < 0.74 \times U_N$ from battery to mains operation for $U > 0.80 \times U_N$															
Test functions																
Functional test	The emergency light function is checked once a week First test takes place 1 hour after putting into operation For the first test, both lamps are switched on for 1 minute and the battery is charged with the rated current. Battery errors and lamp faults are detected and indicated via the LED.															
Light duration test of the emergency lighting	Automatic light duration test function integrated in the light; Activation of the function: remove the jumper between the terminals 9 and 12. After having removed the bridge between the terminals 9 and 12, the test function is activated as soon as the light is connected to the mains and repeated automatically after time has elapsed. Test of the battery capacity in time intervals of 6 months; operation of the device in the emergency light mode during 2/3 of rated operation time. If the light is switched off by the discharge protection before the time has elapsed, the battery cannot be used for the emergency mode. The red LED indicates the error.															

# Emergency Light Fitting for Fluorescent Lamps

Series EXLUX 6008 / 6408



E2







## Technical Data

Function indicators	1 LED red and 1 LED green, located in the reflector sheet, can be seen from the outside through the lamp cover	
	LED	Indication
	Green	On Blinking
	Red	On Blinking Flashing
	Green/ Red	Blinking
	Blinking	1 s ON 1 s OFF
	Flashing	0.25 s ON 1.75 s OFF
Operating modes	<p>On delivery, the light is wired for a continuous operation; if the jumper between the terminals 9 and 10 of the emergency light electronics is removed and an external switch F is connected, the continuous mode with switchable emergency light is activated.</p> <p>Terminal block diagram showing terminals 9 and 10. A jumper connects terminals 9 and 10 for 'Maintained operation'. An external switch F is connected between terminals 9 and 10 for 'Maintained operation with switchable emergency lighting'.</p>	
	<p>Function description</p> <p><b>Continuous operation</b> In case of a power failure of the general lighting system, the battery will supply the light with power independently of the light switch position.</p> <p><b>Continuous operation with switchable emergency light blocking</b> In case of a power failure for the general lighting system, the light is only switched to the emergency light mode if the external switch F is closed. The external switch switches the emergency light automatically to "Ready" or "Not ready" depending, for example, on the operating times of the system; the external switch is equipped with a potential-free contact.</p> <p>A maximum number of 30 lights can be connected to each external switch with series connection or 50 lights in a star-like arrangement. The cable length must not exceed 500 m. Cross section of the cable: at least 1.5 mm<sup>2</sup></p>	
<b>Battery set</b>	<p>Version Gas-tight NiCd battery</p> <p>Operating voltage 6 V</p> <p>Capacity 7 Ah</p> <p>Replacing the battery set When the battery enclosure is opened, the battery set is de-energised; the battery set can be removed from the enclosure after disconnection of the plug-in contacts</p>	

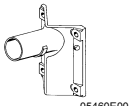
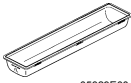
## Emergency Light Fitting for Fluorescent Lamps

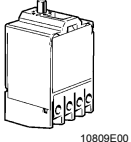
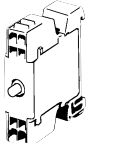
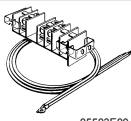
Series EXLUX 6008 / 6408

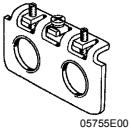
### Accessories and Spare Parts

Designation	Illustration	Description	Art. no.	Weight kg	
Fluorescent lamps	 04936E00	18 W    1350 lm	<b>108952</b>	0.100	
		36 W    3350 lm	<b>108951</b>	0.200	
Bracket for wall mounting with tube	 05460E00	for side entry lamp; with tube, length 400 mm, $\varnothing$ 42 mm	<b>108947</b>	2.480	
Lamp cover	 05329E00	for lamp 18 W	<b>115814</b>	0.800	
		for lamp 36 W	<b>115817</b>	1.500	
Pole mount adapter	 05500E00	for the subsequent mounting on lights 18 W and 36 W, completely with assembly parts	<b>115698</b>	2.100	
Switch	 10809E00	Switching element 8080/1-3-L, 2 normally closed contacts	<b>132527</b>	0.025	
		 13556E00	Switching element 8082/1-2-00, 1 NO contact	<b>132640</b>	0.030
Mounting kit for through wiring	 05503E00	for lights 36 W L1, L <sup>1</sup> , N, PE (4 x 2.5 mm <sup>2</sup> , max. 16 A)	<b>116358</b>	0.200	
		for lights 36 W L1, L2, L3, L <sup>1</sup> , N, PE (6 x 2.5 mm <sup>2</sup> , max. 16 A)	<b>116359</b>	0.340	
		for lights 36 W (spring cage terminal) L1, L <sup>1</sup> , N, PE (4 x 2.5 mm <sup>2</sup> , max. 16 A)	<b>169693</b>	0.307	
		for lights 36 W (spring cage terminal) L1, L2, L3, L <sup>1</sup> , N, PE (6 x 2.5 mm <sup>2</sup> , max. 16 A)	<b>169694</b>	0.417	
Reflectors	 05324E00	for lights with two lamps 18 W	<b>115716</b>	1.105	
		for lights with two lamps 36 W	<b>115745</b>	2.070	
Socket key	 05321E00	M8 / wrench size 13; to open/close the central locking	<b>140486</b>	0.126	
Adapter plates	 05755E00	1 x M20 x 1.5	1 piece	<b>115815</b>	0.070
		1 x M25 x 1.5	1 piece	<b>115818</b>	0.070
		1 x NPT 1/2"	1 piece	<b>115821</b>	0.070
		1 x NPT 3/4"	1 piece	<b>115824</b>	0.070
		2 x M20 x 1.5	1 piece	<b>115826</b>	0.060
		2 x M25 x 1.5	1 piece	<b>115828</b>	0.060
		2 x NPT 1/2"	1 piece	<b>115829</b>	0.060
Battery set	 05567E00	Gas-tight NiCd battery; 7 Ah / 6 V	<b>118013</b>	1.000	







# Emergency Light Fitting for Fluorescent Lamps

Series EXLUX 6008 / 6408

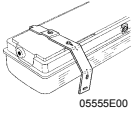

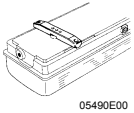
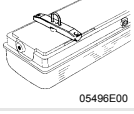
E2

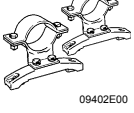
## Accessories and Spare Parts

Designation	Illustration	Description	Art. no.	Weight kg
Wall mounting bracket 90°	 05555E00	Material: stainless steel 1 pair	<b>115713</b>	1.500
Wall mounting bracket 50°	 05556E00	Material: stainless steel 1 pair	<b>115691</b>	1.200
Ring bolt	 05378E00	M8, direct mounting in insert nuts, 1 pair	<b>115736</b>	0.120
Mounting rail	 05490E00	for a variable mounting distance 1 pair	<b>115719</b>	0.330
Mounting bracket	 05498E00	Mounting clamp mounted on a mounting rail for a variable mounting distance; 1 pair	<b>115777</b>	0.400
Top rail	 05493E00	for ceiling suspension of the lamp 1 pair	<b>115733</b>	0.280
Pipe clamp	 09402E00	R 1 1/2"	<b>115690</b>	1.250
		R 2"	<b>115711</b>	1.370
		R 1 1/4"	<b>115728</b>	1.250
Breathing gland	 05703E00	M25 x 1.5 in order to avoid condensate formation	<b>115738</b>	0.020

## Dimensional Drawings (All Dimensions in mm) - Subject to Alterations

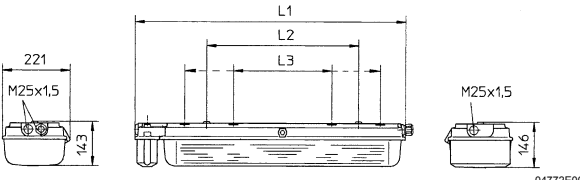

04772E00

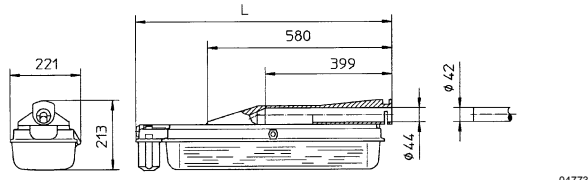

04773E00

Dimensions in mm	Light		Dimensions in mm	Light	
	18 W	36 W		18 W	36 W
L1	782	1392	L	806	1416
L2 <sup>1)</sup>	400	800			
L3 <sup>2)</sup>	312 ... 465	670 ... 865			

<sup>1)</sup> fixed mounting distance  
<sup>2)</sup> variable mounting distance

**EXLUX 6008 und EXLUX 6408 Standard Light**

**EXLUX 6008 und EXLUX 6408 Side Entry Lamp**

We reserve the right to make alterations to the technical data, weights, dimensions, designs and products available without notice. The illustrations cannot be considered binding.

Representante oficial de:



[Argentina – Uruguay – Paraguay – Bolivia – Ecuador.]



Calle 49 N° 5764 - Villa Ballester (B1653AOX) - Prov. de Buenos Aires - ARGENTINA  
Tel: (+54 11) 4768-4242 / Fax: (+54 11) 4849-1212  
Mail: [ventas@nakase.com.ar](mailto:ventas@nakase.com.ar) / Web: [www.nakase.com.ar](http://www.nakase.com.ar)

---

